

WIRING INSTRUCTIONS

TITLE

2-SPEED HOLE HAWG

MILWAUKEE ELECTRIC TOOL CORP.

13135 WEST LISBON RD. BROOKFIELD, WIS

Date
Feb. '73

BULLETIN

58-01-0622

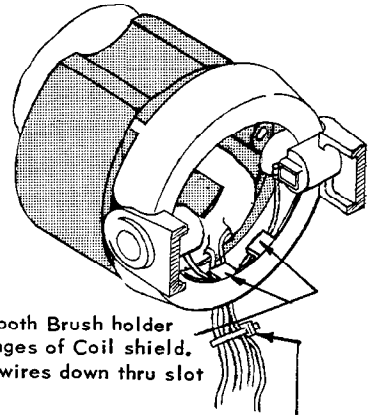
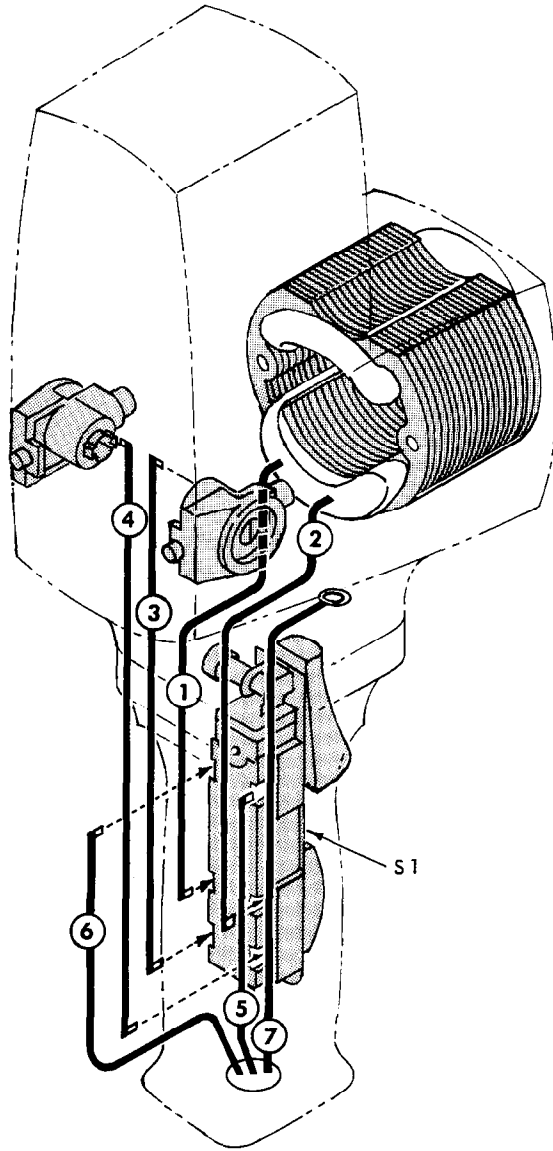

Important: Run both Brush holder leads under flanges of Coil shield. Then dress the wires down thru slot in Coil shield

Field and Brush Holder Wires Should be tied Together with Wire Tie 23-78-0100

REFER TO ELECTRICAL PARTS CHART FOR TERMINAL AND CONNECTOR PART NOS. AND QUANTITY REQUIRED ~ SEE DRAWING FOR ACTUAL HOOK-UP.

WIRING SPECIFICATIONS

Wire Color	Wire No.	Ga.	Lgth.	Terminal				Connector				Wire Color	Wire No.	Ga.	Lgth.	Terminal				Connector													
				T1	T2	T3	T4	C1	C2	C3	C4					T1	T2	T3	T4	C1	C2	C3	C4										
Yellow	1	Field	5-5/8	X																													
Black	2	Field	5-5/8	X																													
Red	3	16	7-1/2	XX																													
White	4	16	7-1/2	XX																													
White	5	Cord	3-7/8	X																													
Black	6	Cord	3-7/8	X																													
Green	7	Cord	7-1/4		X																												

NOTE:
ALL LEADS MUST BE HELD TO ± 1/8"
ALL FIELD LEADS TO BE MEASURED FROM
AND PERPENDICULAR TO LAMINATIONS.
ALL LEAD LENGTHS ARE BEFORE STRIPPING.

Electrical Parts

TERMINAL DESCRIPTION		
Code	Part No.	Qty.
T1	22-44-0090	8
T2	23-74-0390	1
CONNECTOR DESCRIPTION		
Code	Part No.	Qty.
SWITCH DESCRIPTION		
Code	Part No.	Qty.
S1	23-66-0751	1